



# Microreactor Research, Development and Demonstrations at Idaho National Laboratory

March 2021

*Changing the World's Energy Future*

Jess C Gehin



**DISCLAIMER**

This information was prepared as an account of work sponsored by an agency of the U.S. Government. Neither the U.S. Government nor any agency thereof, nor any of their employees, makes any warranty, expressed or implied, or assumes any legal liability or responsibility for the accuracy, completeness, or usefulness, of any information, apparatus, product, or process disclosed, or represents that its use would not infringe privately owned rights. References herein to any specific commercial product, process, or service by trade name, trade mark, manufacturer, or otherwise, does not necessarily constitute or imply its endorsement, recommendation, or favoring by the U.S. Government or any agency thereof. The views and opinions of authors expressed herein do not necessarily state or reflect those of the U.S. Government or any agency thereof.

# **Microreactor Research, Development and Demonstrations at Idaho National Laboratory**

**Jess C Gehin**

**March 2021**

**Idaho National Laboratory  
Idaho Falls, Idaho 83415**

**<http://www.inl.gov>**

**Prepared for the  
U.S. Department of Energy  
Under DOE Idaho Operations Office  
Contract DE-AC07-05ID14517**

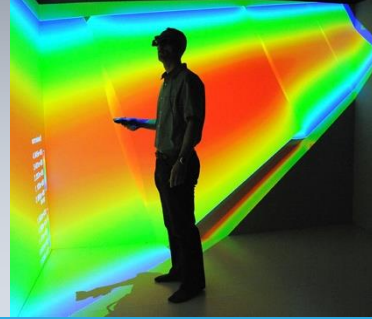
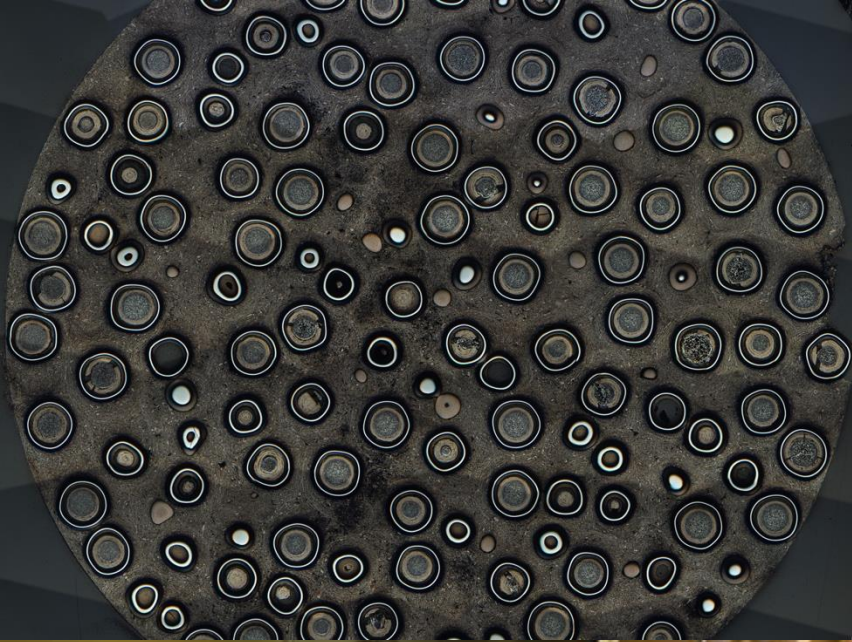

March 10, 2021

**Jess C. Gehin, Ph.D.**

Associate Laboratory Director, Nuclear  
Science & Technology Directorate

Jess.Gehin@inl.gov

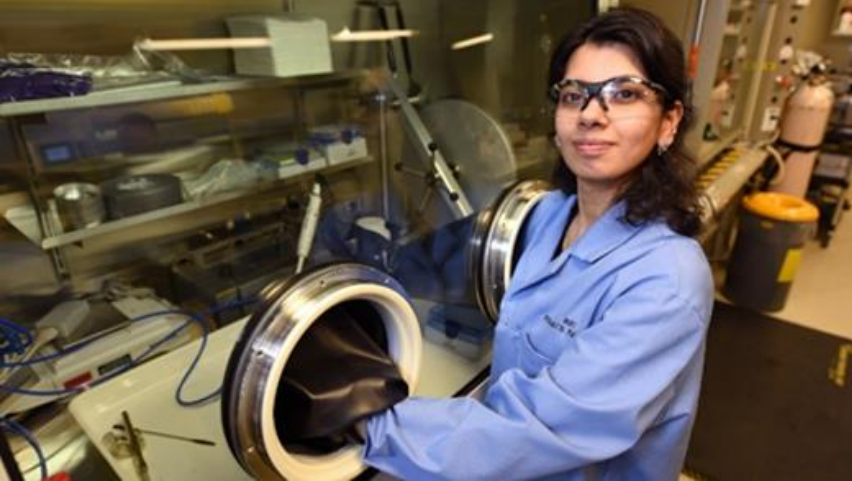

# Microreactor Research, Development and Demonstrations at Idaho National Laboratory

# INL – Inspired by the past to change the future

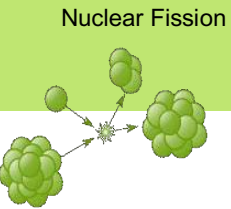
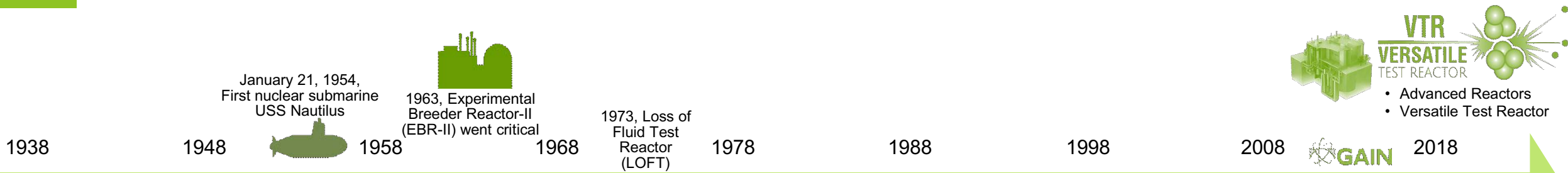

December 20, 1951, Experimental Breeder Reactor-I (EBR-I)

1959, Transient Reactor Test Facility (TREAT)

1972, Power Burst Facility (PBF)

1967, Advanced Test Reactor (ATR) critical

1986, EBR-II demonstrates inherent reactor safety

2007, Nuclear Science User Facilities

NRIC

2018, TREAT restarted

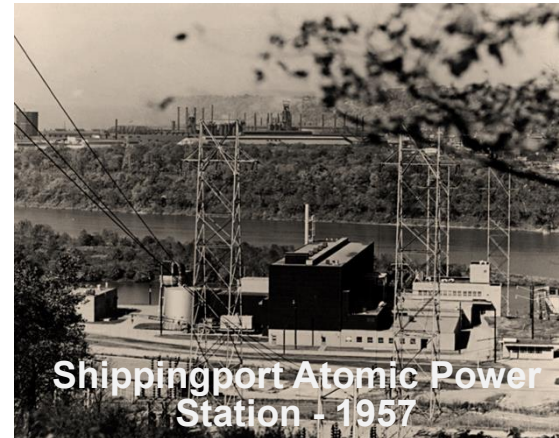
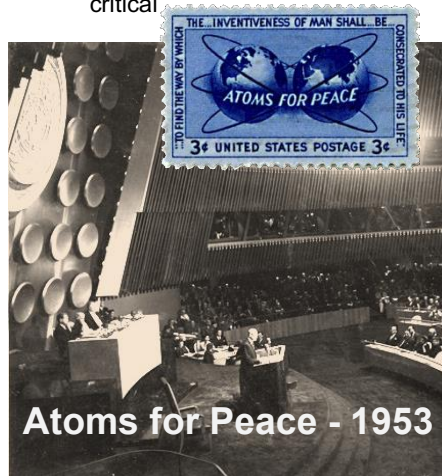

# Vision for advanced reactor demonstrations and deployment

## Microreactor Demonstrations

- Resolve key advanced reactor issues
- Open new markets for nuclear energy
- Provide a “win” to build positive momentum
- 2022-23 MARVEL startup
- Civilian and federal apps

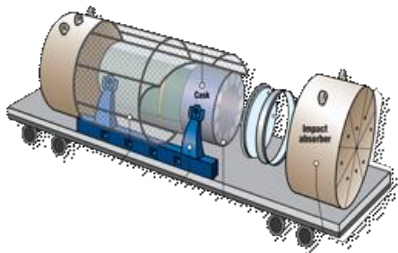

2025

## Microreactors deployed

- Support deployment for remote site power and process heat customers
- RD&D to enable broader deployment

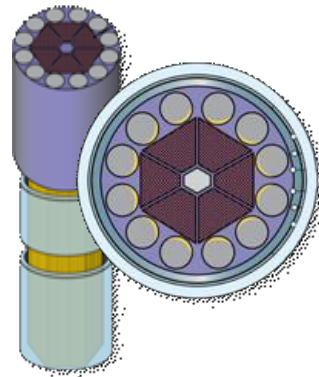

## Versatile Test Reactor (VTR) operating

- Establish fast-spectrum testing and fuel development capability
- Support non-LWR advanced reactor demonstrations

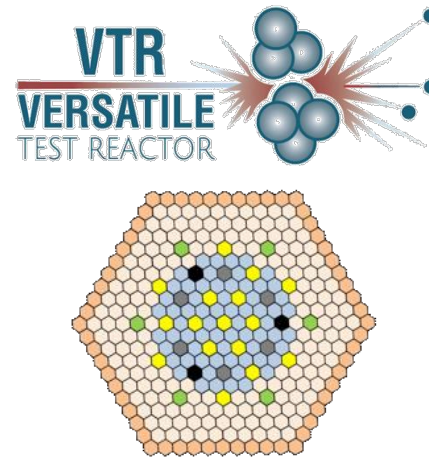

## Advanced reactor demonstrations

- DOE-NE Advanced Reactor Demonstration Program
- Demonstrate two advanced reactors

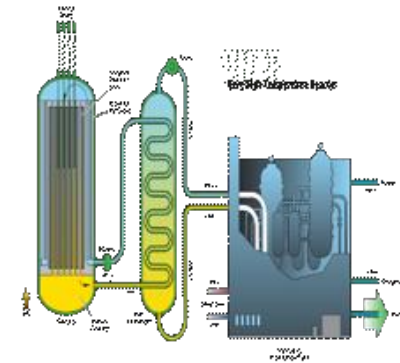

2028

## Small Modular Reactors operating

- Enable deployment through siting and technical support
- 2029 - First NuScale module (UAMPS) to commence commercial operation

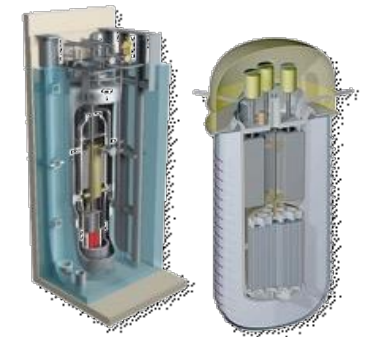

2029

# National Reactor Innovation Center

## Dr. Ashley Finan, Director

The National Reactor Innovation Center (NRIC), established by the U.S. Department of Energy in August 2019 to accelerate the demonstration and deployment of advanced nuclear energy

### 5 – Year Program Objectives:

- **Enable demonstration of at least 2 advanced reactors**
  - Make available infrastructure, sites, materials, expertise
  - Provide regulatory support
  - Best practices in public engagement
- **Prepare DOE/labs for continuing innovation and demonstration**
  - Develop best practices for planning/construction/demonstration of nuclear projects
  - Develop enduring infrastructure and expertise
  - Establish methods for efficient coordination among laboratories

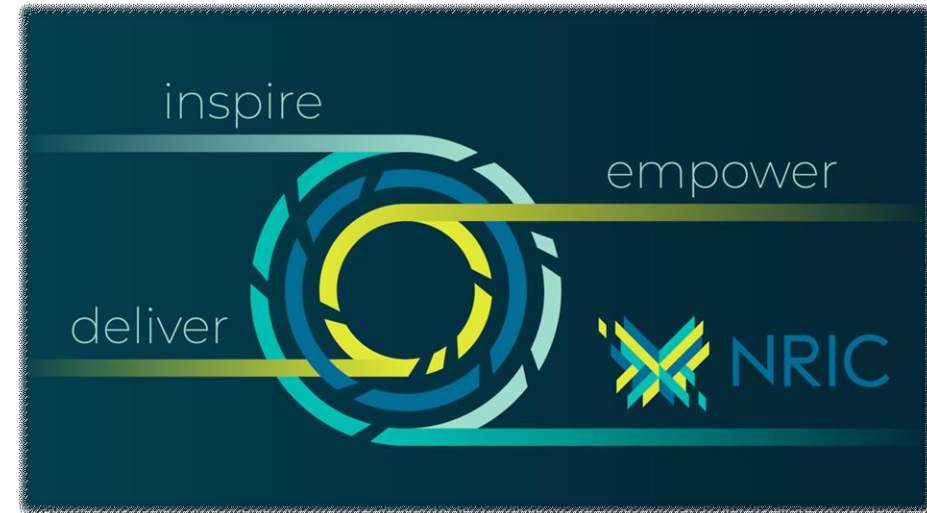

# NRIC Is Developing Test Beds to Support Advanced Reactor Demonstrations

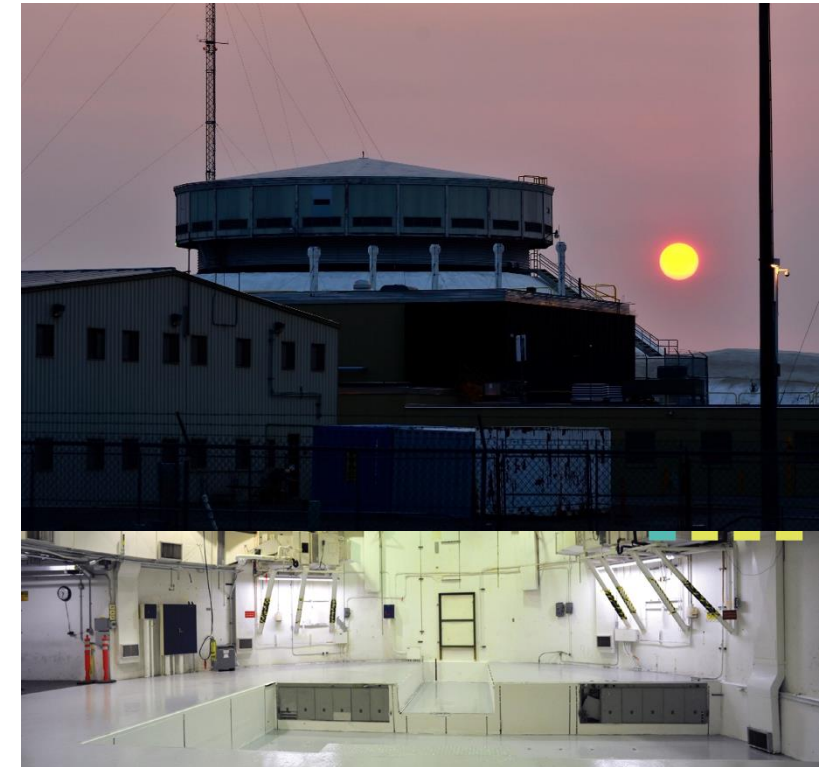

- Enable continuing innovation by refurbishing and leveraging existing infrastructure for multiple demonstration projects
  - Conceptual design planned for 2021

# DOE Microreactor Program

Dr. John Jackson (INL), National Technical Director

## Program Vision

**Through cross-cutting research and development and technology demonstration support, by 2025 the Microreactor Program will:**

- Achieve technological breakthroughs for key features of microreactors
- Empower initial demonstration of the next advanced reactor in the US
- Enable successful demonstrations of multiple domestic commercial microreactors.

## Program Objectives

- Address critical cross cutting R&D needs that require unique laboratory/university capability or expertise
- Develop R&D infrastructure to support design, demonstration, regulatory issue resolution, and M&S code validation
- Develop advanced technologies that enable improvements in microreactor viability

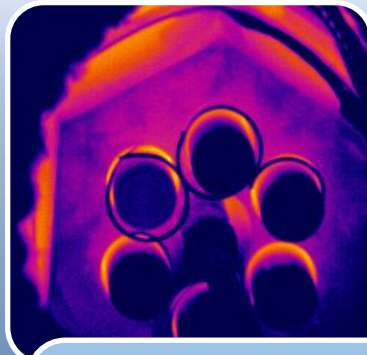
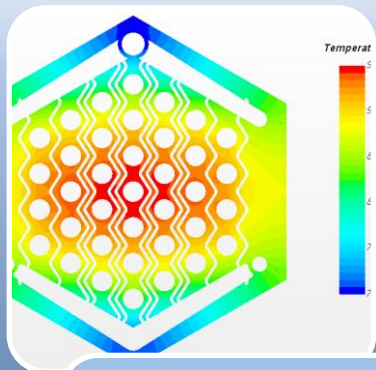

### System Integration & Analyses

- Economics & Market Analysis
- Integrated Systems Analysis
- Applications of NEAMS computational Tools
- Technoeconomic Analyses
- Regulatory Development

### Technology Maturation

- Advanced Heat Pipes
- Advanced Moderators
- Heat Exchangers
- Instrumentation & Sensors
- Advanced Materials and Material Code cases

### Demonstration Support Capabilities

- Non-nuclear thermal and integration testing
- Microreactor Agile Non-nuclear Experimental Testbed (MAGNET)
- Microreactor Applications Research, Validation <sup>[SEP]</sup> and Evaluation (MARVEL)

### Microreactor Demonstrations & Applications

- Reactor Demonstrations
- Remote heat & power
- Hydrogen co-generation
- District heating
- Desalination

# Single Primary Heat Extraction and Removal Emulator (SPHERE)

- **Provide capabilities to perform steady state and transient testing of heat pipes and heat transfer:**
  - Wide range of heating values and operating temperatures
  - Observe **heat pipe startup and transient operation**
- **Develop effective thermal coupling methods between the heat pipe outer surface and core structures**
- **Measure heat pipe axial temperature profiles during startup, steady-state, and transient operation using thermal imaging and surface measurements**

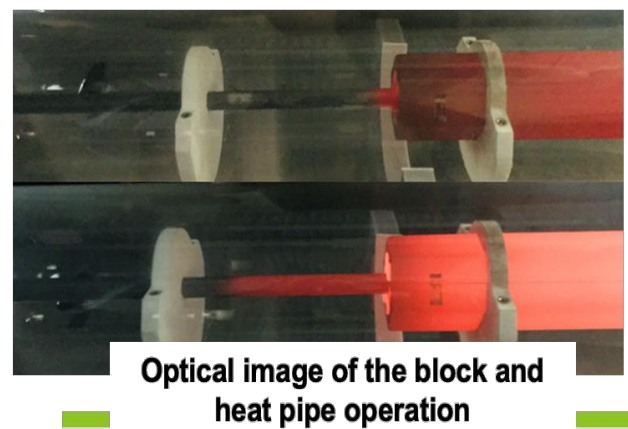
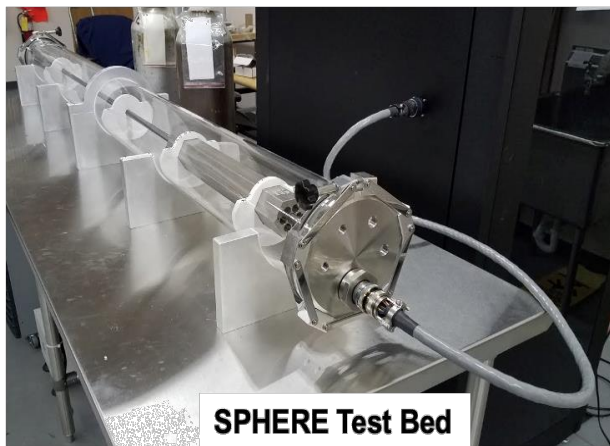

Parameter	Value
Length	243 cm
Diameter	15 cm
Tube material	Quartz
Connections	Flanged for gas flow and instrumentation feed through
Maximum power	20 kW
Max Temperature	750 C
Heat Removal	Passive radiation or water-cooled gas gap calorimeter

# Microreactor AGile Non-nuclear Experiment Testbed (MAGNET)

- General-purpose test bed for performance evaluation of microreactor design concepts (heat pipe, gas-cooled, other).
- Provide detailed reactor core and heat removal section thermal hydraulic performance data for prototypical geometries and operating conditions.
- Demonstrate interface of heat removal section to power conversion system for power generation.
- Provides for integrated materials, instrumentation testing
- Co-located with integrated energy systems R&D capabilities

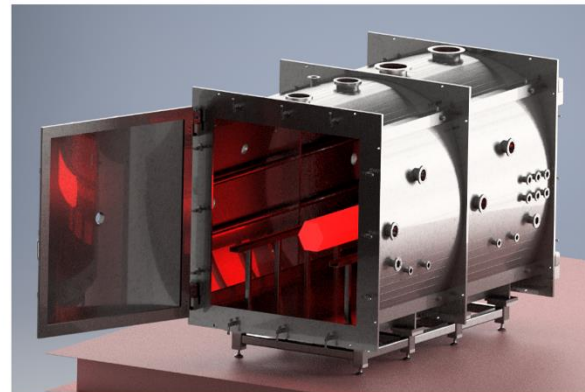
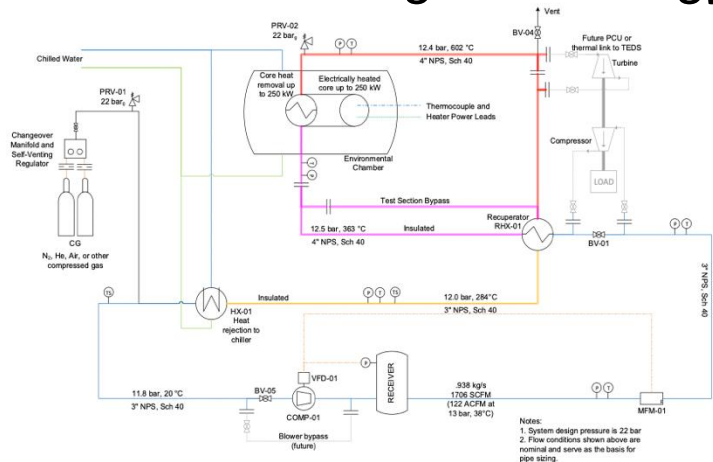

Parameter	Value
Chamber Size	5 ft x 5 ft x 10 ft
Heat Removal	Liquid-cooled chamber walls, gas flow
Connections	Flanged for gas flow and instrumentation feed through and viewing windows
Coolants	Air, inert gas (He, N2)
Gas flow rates	Up to 43.7 ACFM at 290 psi <sub>g</sub>
Design pressure	22 bar <sub>g</sub>
Maximum power	250 kW
Max Temperature	750 C
Heat Removal	Passive radiation or water-cooled gas gap calorimeter

# MAGNET is in the INL Energy Systems Laboratory for research on integrated energy systems

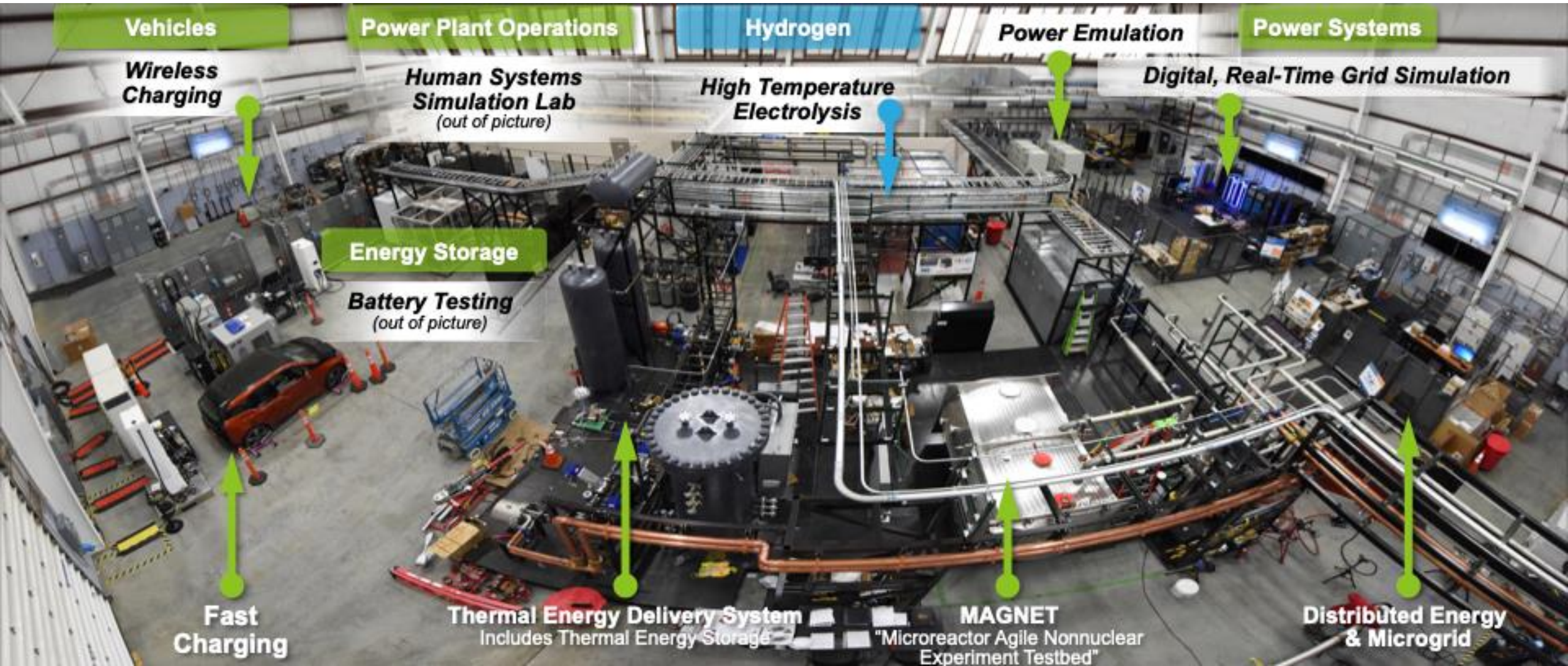

# MARVEL – Microreactor Applications Research, Validation & Evaluation Project

- Project Goal: Rapid development of a small scale microreactor that provides a platform to research and development on unique operational aspects and integration with end use applications of microreactors
- Supported by the DOE Microreactor Program and National Reactor Innovation Center
  - MRP: Engage with microreactor end-user companies
  - NRIC: Develop and exercise capabilities to execute reactor demonstration projects
- Project Schedule: Planned operations by late 2022 - early 2023
- Anticipating applications testing:
  - Microgrid integration
  - Remote power and heat for computing, water, buildings, etc.
  - Currently engaging interested end users for testing activities



A conceptual rendering of the MARVEL Reactor in INL's TREAT Facility

# MARVEL Reactor Overview



Parameter	Value
Reactor Thermal Power	100 kW
Nominal Electrical Output	20 kWe
High-grade heat	~45 kWt at 450 C
Coolant	NaK, natural circulation
Fuel	UZrH
Reactivity control	4 control drums
Location	INL, TREAT Facility

# INL Fission Battery Initiative - Defining the next generation of nuclear energy technology

**Vision:** Developing technologies that enable nuclear reactor systems to function as batteries.

**Outcome:** Deliver on research and development needed to provide technologies that achieve key fission battery attributes and expand applications of nuclear reactors systems beyond concepts that are currently under development.

- **Economic** – Cost competitive with other distributed energy sources (electricity and heat) used for a particular application in a particular domain.
- **Standardized** – Developed in standardized sizes, power outputs, and manufacturing processes that enable universal use and factory production, thereby enabling low-cost and reliable systems with faster qualification and lower uncertainty for deployment.
- **Installed** – Readily and easily installed for application-specific use and removal after use. After use, fission batteries can be recycled by recharging with fresh fuel or responsibly dispositioned.
- **Unattended** – Operated securely and safely in an unattended manner to provide demand-driven power.
- **Reliable** – Equipped with systems and technologies that have a high level of reliability to support the mission life and enable deployment for all required applications. They must be robust, resilient, fault tolerant, and durable to achieve fail-safe operation.

## Workshop Series – Remaining Workshops

### Transportation and Siting for Fission Batteries

📅 March 15, 2021 | 12 pm to 5 pm [Register here](#)

Abhinav Gupta (NCSU), Elmar Eidelpes (INL), & Abdollah Shafieezadeh (The Ohio State University)

### Safeguards and Security of Fission Batteries

📅 April 2, 2021 | 10 am to 5 pm [Register here](#)

Gustavo A. Reyes (INL), Carol Smidts (The Ohio State University), & Cassiano Ricardo (UNM)

### Safety and Licensing of Fission Batteries

📅 April 16, 2021 | 10 am to 4 pm [Register here](#)

Maria Avramova (NCSU), Dean Wang (The Ohio State University), & Jason A. Christensen (INL)

# Resources

- **INL Microreactor Information**
  - <https://inl.gov/trending-topic/microreactors/>
- **National Reactor Innovation Center**
  - <https://nric.inl.gov>
- **Gateway for Accelerated Innovation in Nuclear**
  - <https://gain.inl.gov/SitePages/Home.aspx>
- **DOE Microreactor Program**
  - <https://gain.inl.gov/SitePages/MicroreactorProgram.aspx>
- **Nuclear Computational Resource Center (code & computing access)**
  - <https://inl.gov/ncrc/>